

WHEN FULL POWER IS NEEDED

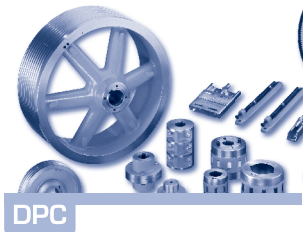

DESCH



- D** Motor Spannschienen
- GB** Motor slide rails
- F** Rails tendeurs á moteur
- I** Slittle tendimotore
- E** Carriles tensores del motor

SP 07

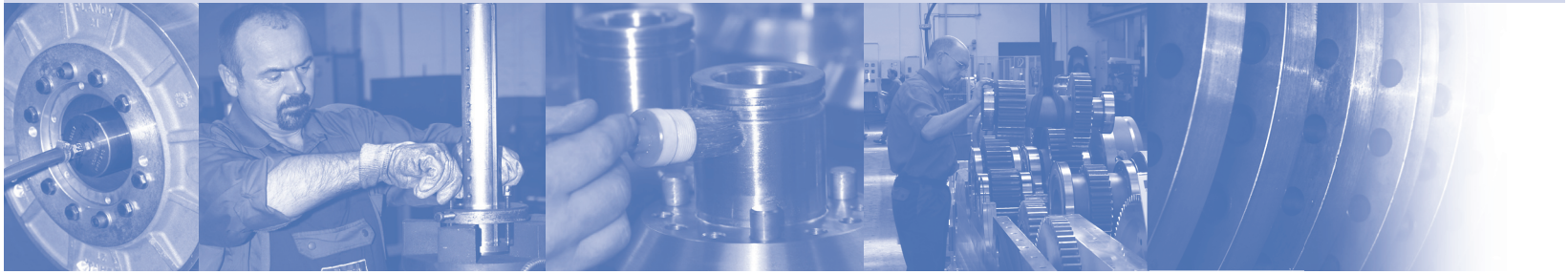

D Motor-Spannschienen

mit vielen Vorteilen:

- bewährte Qualität
- in vielen Nennlängen lieferbar
- einfach in der Montage
- langlebig, da kaum korrosionsgefährdet
- lärmdämpfend und umweltfreundlich
- kurzfristig lieferbar
- universell einsetzbar
- niedrig im Preis
- daher wirtschaftlich

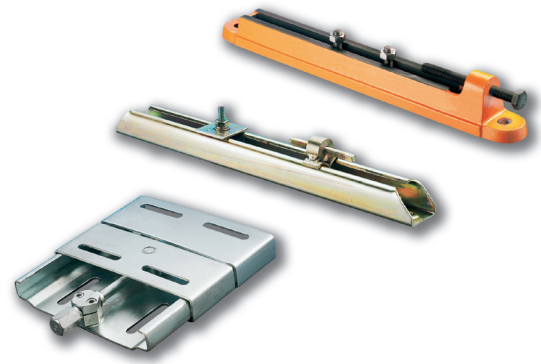

GB Motor slide rails

with many advantages:

- proven quality
- available in many nominal lengths
- simple to assemble
- long life because hardly any danger of corrosion
- noise damping and environmentally friendly
- universally usable
- low price
- therefore economic

F Rails tendeurs á moteur

avec un grand nombre d'avantages :

- qualité éprouvée
- disponible en un grand nombre de longueurs nominales
- montage aisé
- longue durée de vie, car pratiquement aucun risque de corrosion
- silencieux et favorable à l'environnement
- possibilité d'utilisation universelle
- prix très avantageux
- et donc économique et rentable

Motor-Spannschienen DIN 42923

- GB** Motor slide rails DIN 42923
- F** Rails tendeurs á moteur DIN 42923
- I** Slittle tendimotore DIN 42923
- E** Carriles tensores del motor DIN 42923

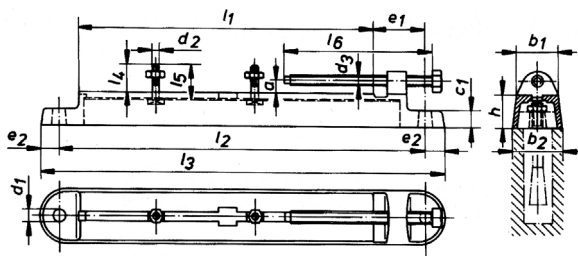

Gleitlänge = 265 bis 500 mm
 Sliding length = 265 by 500 mm
 Longuer de glissement = 265 á 500 mm
 Corsa di scorrimento = 265 fino 500 mm
 Longitud de deslizamiento = 265 a 500 mm

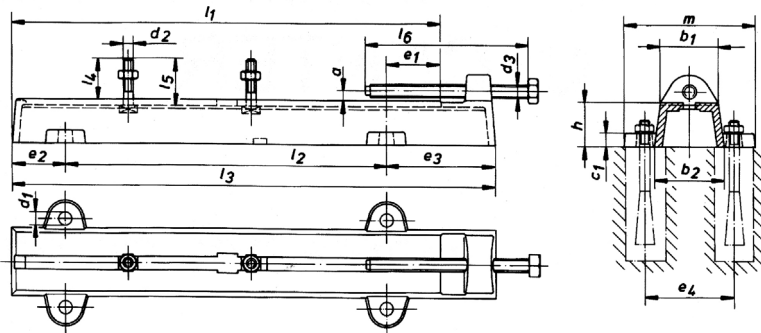

Gleitlänge = 630 bis 1000 mm
 Sliding length = 630 by 1000 mm
 Longuer de glissement = 630 á 1000 mm
 Corsa di scorrimento = 630 fino 1000 mm
 Longitud de deslizamiento = 630 a 1000 mm

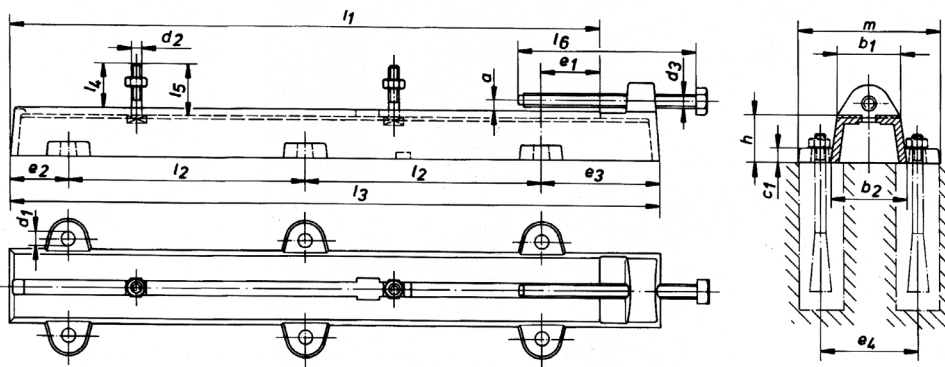

Gleitlänge = 1250 mm
 Sliding length = 1250 mm
 Longuer de glissement = 1250 mm
 Corsa di scorrimento = 1250 mm
 Longitud de deslizamiento = 1250 mm

Gleitlänge/ Sliding length/ Longuer de glissement/ Corsa di scorrimento/ Longitud de deslizamiento	a	b ₁	b ₂	c ₁	d ₁	e ₁	e ₂	e ₃	e ₄	h	l ₂	l ₃	l ₄	m	Biegemoment Bending moment/ Moment de flexion/ Momento flector/ Momento flettente
l ₁															M _b
mm	mm	mm	mm	mm	mm	mm	mm	mm	mm	mm	mm	mm	mm	mm	Nm
265	6	40	50	18	10	45	15	-	-	35	325	355	28	-	80
315	8	45	55	18	12	55	20	-	-	35	390	430	28	-	100
355	8	50	65	23	12	55	20	-	-	40	430	470	37	-	200
400	8	55	70	25	15	65	25	-	-	45	480	530	37	-	400
500	12	70	85	30	19	80	30	-	-	55	610	670	50	-	700
630	12	85	100	35	19	80	80	160	130	65	470	710	58	182	1000
800	16	100	120	35	28	100	100	200	165	75	600	900	76	225	2500
1000	16	120	140	40	28	140	140	240	190	80	720	1100	82	250	4000
1250	16	120	140	35	28	140	140	240	190	80	485	1350	-	-	4500

Gleitlänge/ Sliding length/ Longuer de glissement/ Corsa di scorrimento/ Longitud de deslizamiento	Befestigungsschrauben für Maschine Fastening bolt for machine Vis de fixation pour machine Vite di fissaggio per la macchina Tornillo de sujeción para máquin	Spannschrauben Clamping bolts Vis de serrage Tiranti a vite Tornillos tensores	Gewicht Weight Poids Peso Preso	Motorgröße Motor size Taille du moteur Dimensiona motor Tamaño motor
l ₁	d ₂ x l ₅	d ₃ x l ₆	kg	
mm	mm	mm		
265	M 8 x 35	M 10 x 120	1,75	80 / 90
315	M 8 x 35	M 12 x 160	2,5	80 / 90
355	M 10 x 45	M 12 x 160	3,25	100
400	M 10 x 45	M 12 x 160	4,25	112 / 132
500	M 12 x 60	M 20 x 240	9	160 / 180
630	M 16 x 70	M 20 x 240	14	200 / 225
800	M 20 x 90	M 24 x 300	25	250 / 280
1000	M 24 x 100	M 24 x 300	40	315
1250	M 24 x 100	M 24 x 300	47,5	

D Werkstoff der Spannschienen: Gusseisen EN-GJL 200. Befestigungsschrauben mit Vierkantkopf und Sechskantmutter für Maschine sowie Spannschrauben werden mitgeliefert. Steinschrauben nach DIN 529 mit Sechskantmutter zur Verankerung sind gesondert zu bestellen.

F Matériau des rails tendeurs : fonte de fer EN- GJL 200. Des vis de fixation à tête carrée et écrous six pans pour la machine ainsi que des vis de serrage sont également fournis. Des boulons de scellement selon DIN 529 avec écrous six pans pour ancrage doivent être commandés séparément.

E Material de los carriles tensores: hierro fundido EN-GJL 200. Se adjuntan tornillos de sujeción con cabeza cuadrada y tuercas hexagonales para máquina, así como tornillos tensores. Los tornillos para empotrar según DIN 529 con tuercas hexagonales para el anclaje se deben solicitar especialmente.

GB Material for slide rails: cast iron EN-GJL 200. Fasteningscrews with square head and hexagonal nuts for machine as well as clamping bolts are supplied. Wall bolts to DIN 529 with hexagonal nuts for anchorage must be ordered separately.

I Materiale delle slitte tenditrici: ghisa EN-GJL 200. La fornitura comprende le viti di fissaggio a testa quadra, i dadi esagonali per la macchina nonché i tiranti a vite. Bulloni di ancoraggio secondo DIN 529 con dadi esagonali vanno ordinati separatamente.

Motor-Spannschienen, leichte Ausführung

- GB** Motor slide rails, easy design
- F** Rails tendeurs á moteur, blessure construction
- I** Slitte tendimotore, leggero versione
- E** Carriles tensores del motor, leichte versión

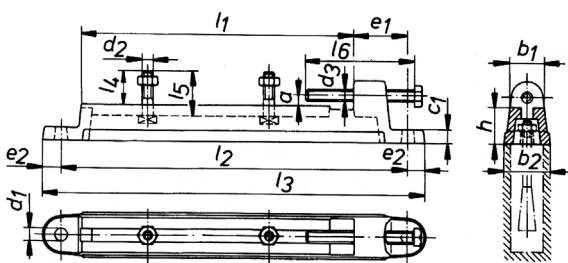

Ausführung A;
 Nennlänge $l_1 = 250$ bis 650 mm
 Design A;
 Nominal length $l_1 = 250$ by 650 mm
 Construction A;
 Longueur nominale $l_1 = 250$ á 650 mm
 Versione A;
 Lunghezza nominale $l_1 = 250$ fino 650 mm
 Versión A;
 Longitud nominal $l_1 = 250$ a 650 mm

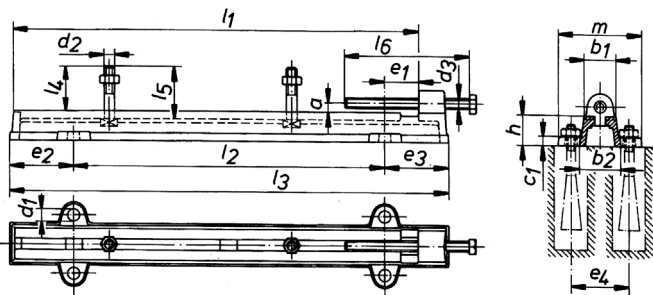

Ausführung B;
 Nennlänge $l_1 = 700$ bis 1500 mm
 Design B;
 Nominal length $l_1 = 700$ by 1500 mm
 Construction B;
 Longueur nominale $l_1 = 700$ á 1500 mm
 Versione B;
 Lunghezza nominale $l_1 = 700$ fino 1500 mm
 Versión B;
 Longitud nominal $l_1 = 700$ a 1500 mm

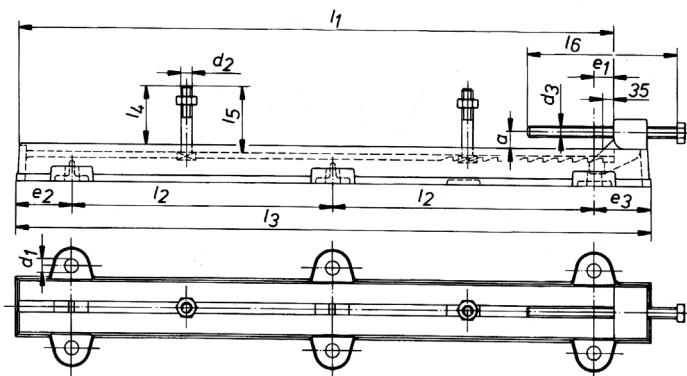

Ausführung C;
 Nennlänge $l_1 = 1600$ bis 2200 mm
 Design C;
 Nominal length $l_1 = 1600$ by 2200 mm
 Construction C;
 Longueur nominale $l_1 = 1600$ á 2200 mm
 Versione C;
 Lunghezza nominale $l_1 = 1600$ fino 2200 mm
 Versión C;
 Longitud nominal $l_1 = 1600$ a 2200 mm



DRIVE TECHNOLOGY

Nennlänge Nominal length Longueur nominale Lunghezza nominale Longitud nominal	a	b ₁	b ₂	c ₁	d ₁	e ₁	e ₂	e ₄	h	l ₂	l ₃	l ₄	m	Biegemoment Bending moment Moment de flexion Momento flector Momento flettente M _B
l ₁ mm	mm	mm	mm	mm	mm	mm	mm	mm	mm	mm	mm	mm	mm	Nm
250	6	30	42	12	12	46	17,5	-	33	315	350	30	-	134
330	8	34	50	13	15	43	22,5	-	35	390	435	35	-	192
400	8	38	55	15	15	43	22,5	-	42	460	505	48	-	285
450	8	40	60	15	15	55	22,5	-	44	530	575	47	-	348
500	8	45	65	18	15	55	22,5	-	48	580	625	47	-	480
550	12	46	65	18	19	55	22,5	-	53	630	675	60	-	527
600	12	50	70	18	19	55	25	-	55	680	730	59	-	428
650	12	54	75	18	19	53	25	-	55	725	775	59	-	466
700	16	65	80	18	19	105	150	115	60	450	750	86	155	653
800	16	68	88	22	19	105	150	120	60	550	850	82	175	768
900	16	70	92	22	19	100	152,5	130	68	650	955	80	185	981
1000	16	75	104	23	24	100	155	140	72	750	1060	100	200	1420
1100	16	80	105	23	24	120	185	140	74	800	1170	100	200	1571
1200	16	85	110	25	24	120	190	140	76	900	1280	100	200	1697
1300	16	85	115	25	28	120	180	160	78	1010	1370	125	225	1788
1400	16	90	120	25	28	145	215	165	80	1050	1480	129	245	2289
1500	16	90	120	30	28	145	215	170	90	1150	1580	122	250	2838
1600	45	140	160	40	28	55	150	220	100	700	1700	152	310	3761
1700	45	140	160	40	28	55	150	220	100	750	1800	152	310	3798
1900	45	160	180	45	28	55	150	250	110	850	2000	150	340	4890
2000	45	180	200	45	35	55	150	280	125	1000	2300	225	370	6950

Nennlänge/ Nominal length/ Longueur nomi- nale/Lunghezza nominale/ Lon- gitud nominal	Befestigungsschrauben für Maschine Fastening bolt for machine Vis de fixation pour machine Vite di fissaggio per la macchina Tornillo de sujeción para máquina	Spannschrauben Clamping bolts Vis de serrage Tiranti a vite Tornillos tensores	Gewicht Weight Poids Peso Preso	Motorgröße Motor size Taille du moteur Dimensiona motor Tamaño motor
l ₁ mm	d ₂ x l ₅ mm	d ₃ x l ₆ mm	kg	
250	M 8 x 40	M 10 x 100	1,5	80/90
330	M 10 x 45	M 12 x 120	2,25	110/112/132
400	M 12 x 60	M 12 x 120	3,25	160/180
450	M 12 x 60	M 12 x 120	4	160/180
500	M 12 x 60	M 12 x 150	6	160/180
550	M 16 x 75	M 16 x 150	7	200/225
600	M 16 x 75	M 16 x 150	8	200/225
650	M 16 x 75	M 16 x 150	8,75	200/225
700	M 20 x 100	M 20 x 200	12,5	250/280
800	M 20 x 100	M 20 x 200	16	250/280
900	M 20 x 100	M 20 x 200	20	250/280
1000	M 24 x 125	M 24 x 300	27	315
1100	M 24 x 125	M 24 x 300	30	315
1200	M 24 x 125	M 24 x 300	35	315
1300	M 24 x 150	M 24 x 350	38,5	315
1400	M 24 x 150	M 24 x 350	47,5	315
1500	M 24 x 150	M 24 x 350	55	315
1600	M 27 x 175	M 30 x 400	102,5	
1700	M 27 x 175	M 30 x 400	107,5	
1900	M 27 x 175	M 30 x 400	152,5	
2200	M 30 x 250	M 30 x 400	205	

D Werkstoff der Spannschienen: Gusseisen EN-GJL 200. Befestigungsschrauben mit Vierkantkopf und Sechskantmutter für Maschine sowie Spannschrauben werden mitgeliefert. Steinschrauben nach DIN 529 mit Sechskantmutter zur Verankerung sind gesondert zu bestellen.

GB Material for slide rails: cast iron EN-GJL 200. Fasteningscrews with square head and hexagonal nuts for machine as well as clamping bolts are supplied. Wall bolts to DIN 529 with hexagonal nuts for anchorage must be ordered separately.

F Matériau des rails tendeurs : fonte de fer EN-GJL 200. Des vis de fixation à tête carrée et écrous six pans pour la machine ainsi que des vis de serrage sont également fournis. Des boulons de scellement selon DIN 529 avec écrous six pans pour ancrage doivent être commandés séparément.

I Materiale delle slitte tenditrici: ghisa EN-GJL 200. La fornitura comprende le viti di fissaggio a testa quadra, i dadi esagonali per la macchina nonché i tiranti a vite. Bulloni di ancoraggio secondo DIN 529 con dadi esagonali vanno ordinati separatamente.

E Material de los carriles tensores: hierro fundido EN-GJL 200. Se adjuntan tornillos de sujeción con cabeza cuadrada y tuercas hexagonales para máquina, así como tornillos tensores. Los tornillos para empotrar según DIN 529 con tuercas hexagonales para el anclaje se deben solicitar especialmente.

Motor-Spannschienen aus Stahl

- GB** Motor slide rails of steel
- F** Rails tendeurs á moteur en acier
- I** Slitte tendimotore in acciaio
- E** Carriles tensores del motor de acero

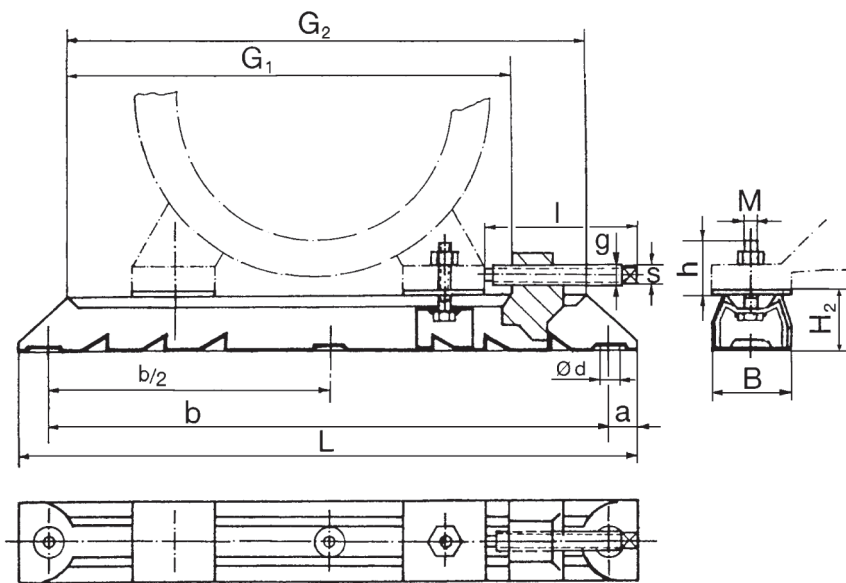

D Befestigungsschrauben und Sechskantmuttern für Maschine sowie Spannschrauben werden mitgeliefert. Steinschrauben nach DIN 529 mit Sechskantmuttern zur Verankerung sind gesondert zu bestellen.

F Des vis de fixation et écrous six pans pour la machine ainsi que des vis de serrage sont également fournis. Des boulons de scellement selon DIN 529 avec écrous six pans pour ancrage doivent être commandés séparément.

E Se adjuntan tornillos de sujeción y tuercas hexagonales para máquina, así como tornillos tensores. Los tornillos para empotrar según DIN 529 con tuercas hexagonales para el anclaje se deben solicitar especialmente

GB Fastening bolts and hexagonal nuts for machine and clamping bolts are supplied. Wall bolts to DIN 529 with hexagonal nuts for anchorage must be ordered separately.

I La fornitura comprende le viti di fissaggio, i dadi esagonali per la macchina nonché i tiranti a vite. Bulloni di ancoraggio secondo DIN 529 con dadi esagonali vanno ordinati separatamente.

**mit versetzbaren Spannkloben/ with movable face plate jaws/
avec bloc de serrage/ con griffa di serraggio traslabile/
con grapas de sujeción desplazables**

Größe Size Taille Grandezza Tamaño	Motorgröße Motor size Taille du moteur Dimensiona motor Tamaño motor	L	B	H ₂	Blechstärke/ Plate thickness/ Épaisseur de tôle/Spes- sore della lamiera/ Espesor de chapa	G ₁	G ₂	a	b	b/2	ød	M x h	l x g x s	kg
		mm	mm	mm	mm	mm	mm	mm	mm	mm	mm	mm	mm	kg
312/6	63/7	312	40	28	2	240	262	16	280		12	M 6 x 19	75 x 10 x 8	1,4
312/8	80/90	312	40	28	2	240	262	16	280		12	M 8 x 27	75 x 10 x 8	1,5
375/6	63/71	375	40	28	2	305	325	16	343		12	M 6 x 19	75 x 10 x 8	1,5
375/8	80/90	375	40	28	2	305	325	16	343		12	M 8 x 27	75 x 10 x 8	1,6
375/10	100/112	375	40	28	2	305	325	16	343		12	M 10 x 32	75 x 10 x 8	1,6
395/8	80/90	395	50	40	3	302	325	20	355		12	M 8 x 28	100 x 12 x 9	3,4
395/10	100/112	395	50	40	3	302	325	20	355		12	M 10 x 35	100 x 12 x 9	3,4
495/8	80/90	495	50	40	3	405	425	20	455		12	M 8 x 29	100 x 12 x 9	4,0
495/10	100/112/132	495	50	40	3	405	425	20	455		12	M 10 x 35	100 x 12 x 9	4,0
495/12	160	495	50	40	3	405	425	20	455		12	M 12 x 49	100 x 12 x 9	4,0
530/10	132	530	60	50	4	413	442	25	480		14	M 10 x 37	120 x 16 x 12	6,4
530/12	160	530	60	50	4	413	442	25	480		14	M 12 x 49	120 x 16 x 12	6,4
630/10	132	630	60	50	4	515	542	25	580		14	M 10 x 37	120 x 16 x 12	8,2
630/12	160/180	630	60	50	4	515	542	25	580		14	M 12 x 45	120 x 16 x 12	8,2
686/12	160/180	686	75	60	4	538	575	25	630	315	15	M 12 x 43	155 x 20 x 17	12,8
686/16	200/225	686	75	60	4	538	575	28	630	315	18	M 16 x 62	155 x 20 x 17	12,8

**mit angeschweißten Spannkloben/ with welded-on face plate jaws/
avec bloc de serrage soudé/ con griffa di serraggio saldata/
con grapas de sujeción soldada**

Größe Size Taille Grandezza Tamaño	Motorgröße Motor size Taille du moteur Dimensiona motor Tamaño motor	L	B	H ₂	Blechstärke/ Plate thickness/ Épaisseur de tôle/Spes- sore della lamiera/ Espesor de chapa	G ₁	G ₂	a	b	b/2	ød	M x h	l x g x s	kg
		mm	mm	mm	mm	mm	mm	mm	mm	mm	mm	mm	mm	kg
864/16	220/225	684	90	75	4	730	810	32	800	400	24	M 16 x 60	340 x 24 x 17	16,6
864/20	250/280	864	90	75	4	730	810	32	800	400	24	M 20 x 68	340 x 24 x 17	16,6
1072/20	250/280	1072	112	100	5	900	995	36	1000	500	30	M 20 x 77	375 x 30 x 24	33,4
1072/24	315	1072	112	100	5	900	995	36	1000	500	30	M 24 x 88	375 x 30 x 24	33,5
1330/24	315/35	1330	130	125	6	115	1215	40	1250	625	30	M 24 x 95	430 x 33 x 27	56,6

Anordnung Motor-Spannschienen

- GB Arrangement of motor slide rails
- F Disposition Rail tendeur de moteur
- I Orientamento slitte tenditrici - motore
- E Disposición de los carriles tensores del motor

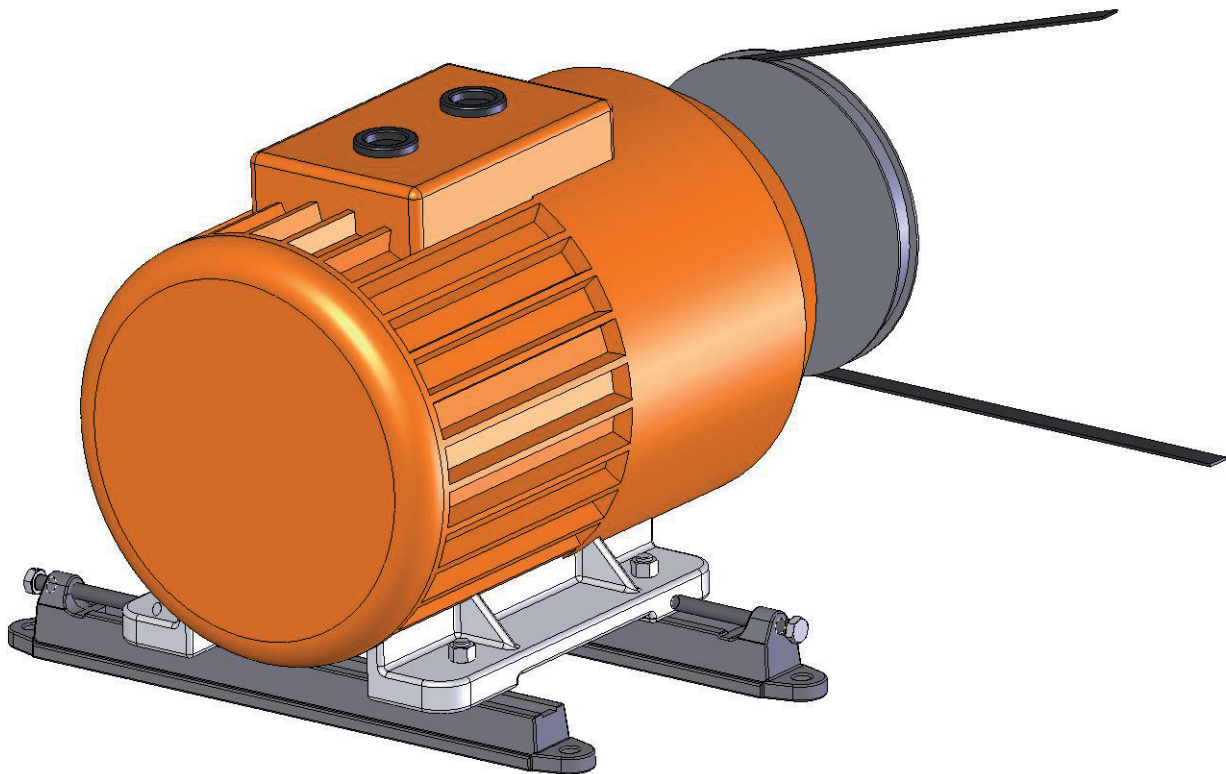
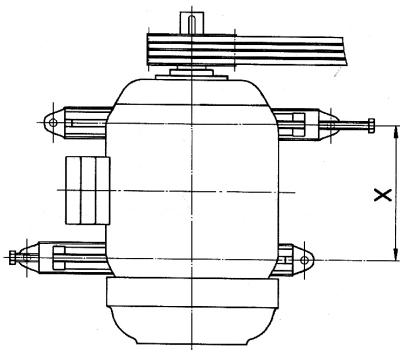

Motor-Spannschlitten aus Stahl

- GB Motor slides of steel
- F Chariot á moteur en acier
- I Slittle per motori in acciaio
- E Carros de motor de acero

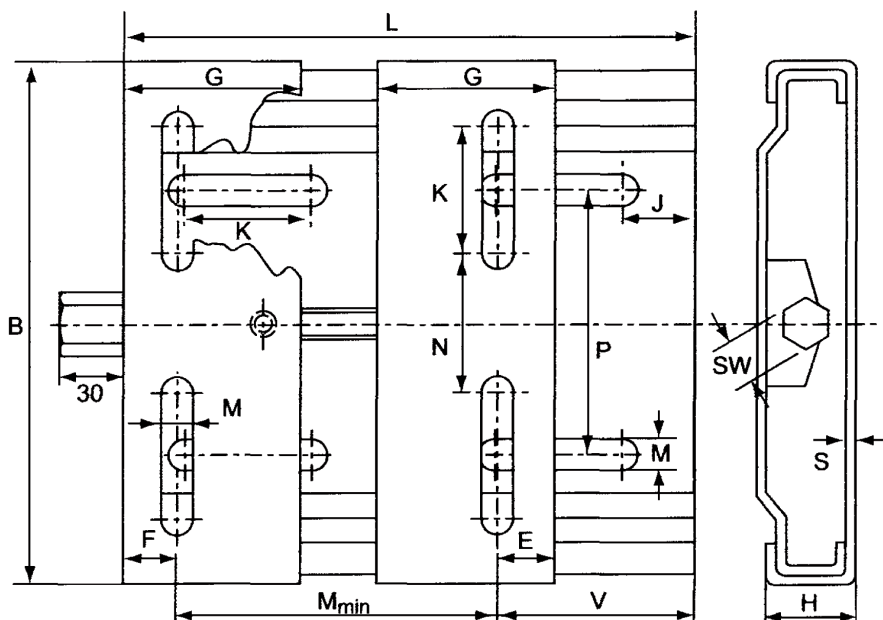

Größe Size Taille Grandezza Tamaño	Motorgröße Motor size Taille du moteur Dimensiona motor Tamaño motor	L	B	H	M _{min}	G	E	J	K	M	N	P	SW	S	kg
mm	mm	mm	mm	mm	mm	mm	mm	mm	mm	mm	mm	mm	mm	mm	mm
210	63 - 80	210	195	33	100	70	20	25	50	10,5	43	98	19	3	2,3
270	63 - 100	270	195	33	100	70	20	25	50	10,5	43	98	19	3	2,7
340	90 - 132	340	290	40	140	95	27	29	62,5	12,5	90	165	22	4	6,3
430	90 - 160	430	290	40	140	95	27	29	62,5	12,5	90	165	22	4	7,4
490	160 - 180	490	410	40	254	95	40	30	60	15	193	142/284	22	4	12,7